



finettiTM
Premium Packaging Tape & Machinery

• INCREASE PRODUCTIVITY & EFFICIENCY • ROBUST & RELIABLE

CT-70

LOW CARTON TAPING MACHINE SIDE DRIVE

- ✓ DESIGNED FOR VERY SMALL CARTONS
- ✓ ROBUST & RELIABLE
- ✓ EASY OPERATION & MAINTENANCE
- ✓ HEAVY DUTY FRAME
- ✓ ADJUSTABLE LEGS FOR EASY HEIGHT ADJUSTMENT

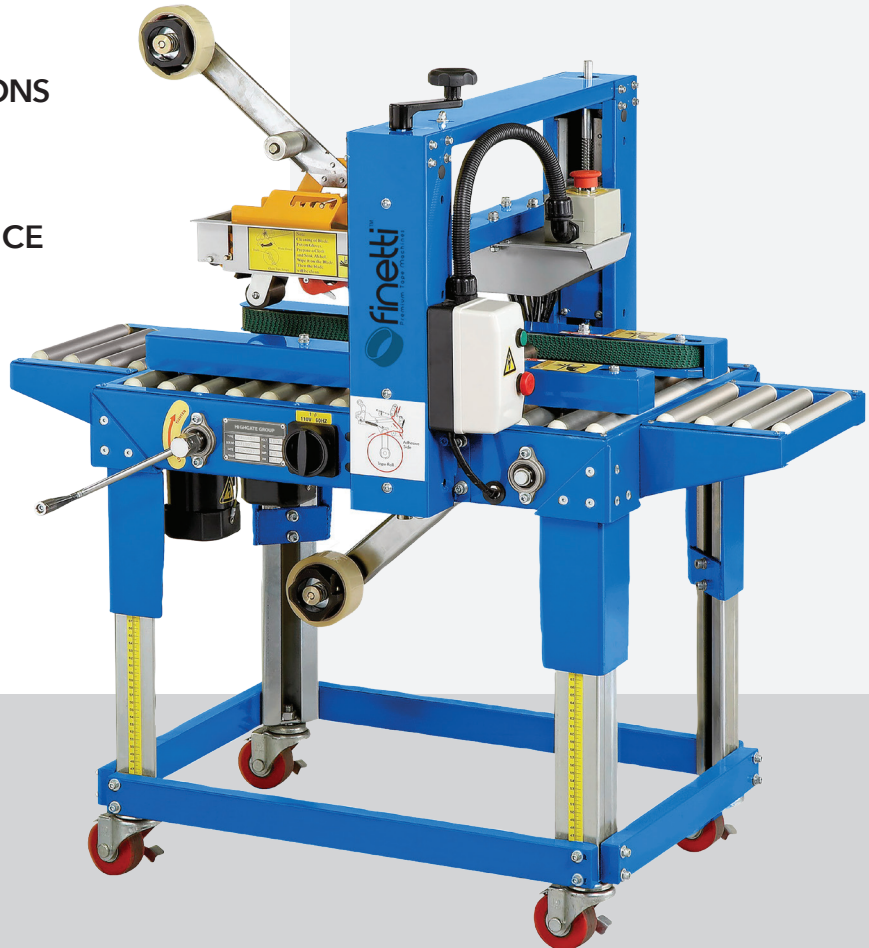

highgate
GROUP

1800 089 456
highgategroup.net.au
sales@highgategroup.net.au

CT-70 LOW CARTON TAPING MACHINE – SIDE DRIVE

TECHNICAL DATA

Product:	Finetti Low Carton Taping Machine - Side Drive
Code:	CT-70
Capacity:	25 boxes/min. For box length 300mm
Dimensions:	730mm (L) x 660mm (W) x 1350mm (H)
Sealing Size:	(L) 120mm ~∞ X (W) 80mm~200mm X (H) 50mm~300mm
Belt Speed:	20m/min
Tape Width:	38mm - 48mm
Power Supply:	240V, 50HZ, Single-Phase

MAIN FEATURES

- Designed for very small cartons
- Robust and reliable.
- Easy operation and maintenance.
- Side belt, power driven.
- Heavy duty frame.
- Adjustable legs for easy height adjustment.
- Castors with brakes.

